

MONSOON

Universal Single Pumps

Universal Single pumps can be used in pairs to boost hot and cold water supplies in vented systems independently, or as a single pump to boost a water supply as required.

Monsoon Universal pumps are fully automatic, do not require a gravity flow of water to start and are suitable for both positive and negative head applications.



Features

- 5 year guarantee
- 2.0 – 4.5 bar options
- Suitable for positive or negative head applications
- Premium quality brass pump supplied with flexible hoses with integral ISO valves
- Very quiet operation
- WRAS approved product
- Continuously rated
- Anti-vibration feet
- EPDM/PTFE/Al. Oxide seal
- Pre-wired with 1.5 metre power cable
- **UK Specification:** Supplied with 22 mm push-in x 300 mm anti-vibration flexible hoses with integral isolating valves
- **ROI Specification:** Supplied with 21 mm push-in x 300 mm anti-vibration flexible hoses with integral isolating valves
- **Export Specification:** Supplied with G 3/4 female x 300 mm long hoses

Application

- Boosting hot and cold water supplies to taps, showers, a complete bathroom or the whole house in low pressure gravity systems
- Suitable for use where there is less than 1 litre/sec flow from the outlet(s) to be boosted

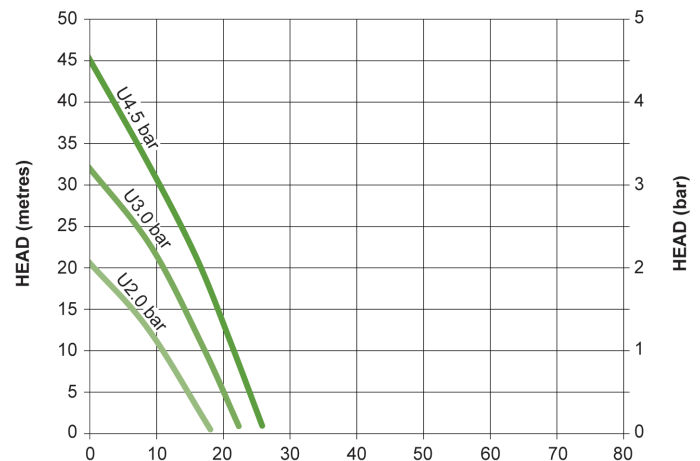

Pump Model		U2.0 bar Single 46498	U3.0 bar Single 46413	U4.5 bar Single 46414
General	Guarantee	5 years		
	WRAS approval	1906076		
	Approvals	WRAS, CE		
Features	Pump type	Peripheral		
	Mechanical seal	EPDM / PTFE / Al. Oxide		
	Anti-vibration feet	✓	✓	✓
	Inlet strainer(s)	✓	✓	✓
	Flexible hoses	2	2	2
	Run on Timer	3 sec	3 sec	3 sec
	Dry run protection	✓	✓	✓
	Noise (dB(A))	42	48	55
Materials	Pump Body	Brass		
	Impeller	Brass		
Performance	Maximum head (closed valve)	2.0 bar (20 metres)	3.2 bar (32 metres)	4.5 bar (45 metres)
	Performance @ 9 l/min	1.2 bar	2.5 bar	3.5 bar
	Performance @ 18 l/min	N/A	0.9 bar	1.7 bar
	Maximum flow	18 l/min	22 l/min	26 l/min
	Maximum static inlet pressure	8 metres	12 metres	
	Maximum static outlet pressure	8 metres	12 metres	
	Maximum working pressure*	600 kPa (6 bar)		
	Maximum ambient air temperature	40 °C		
	Min / Max water temperature**	Min 4 °C / Max 65 °C		
	Flow switch sensitivity (approx)	0.6 l/min		
	Pressure vessel air pre-charge	0.9 bar (13 psi)	1.3 bar (18.5 psi)	
Connections	Pump connections	G ¾ male		
Flexible hoses	Connections (UK model)	G ¾ female x 22 mm push-in x 300 mm long, isolating valves on all hoses		
	Connections (ROI model)	G ¾ female x 21 mm push-in x 300 mm long, isolating valves on all hoses		
	Connections (Export model)	G ¾ female x G ¾ female x 300 mm long		
Motor	Type	Induction, auto-reset thermal trip		
	Duty rating	Continuous (S1) @ 9 l/min and above		
Electrical	Power supply / phase / frequency	230 V a.c. / 1 / 50 Hz		
	Current (full load)	1.1 Amps	1.7 Amps	2.5 Amps
	Power consumption	250 Watts	390 Watts	555 Watts
	Fuse rating	5 Amps		
	Power cable (pre-wired)	1.5 metres		
Physical	Enclosure protection	IPX4		
	Length	200 mm		
	Width	162 mm		
	Height (excluding hoses)	243 mm		
	Weight (including fittings)	6.6 Kg		7.3 Kg

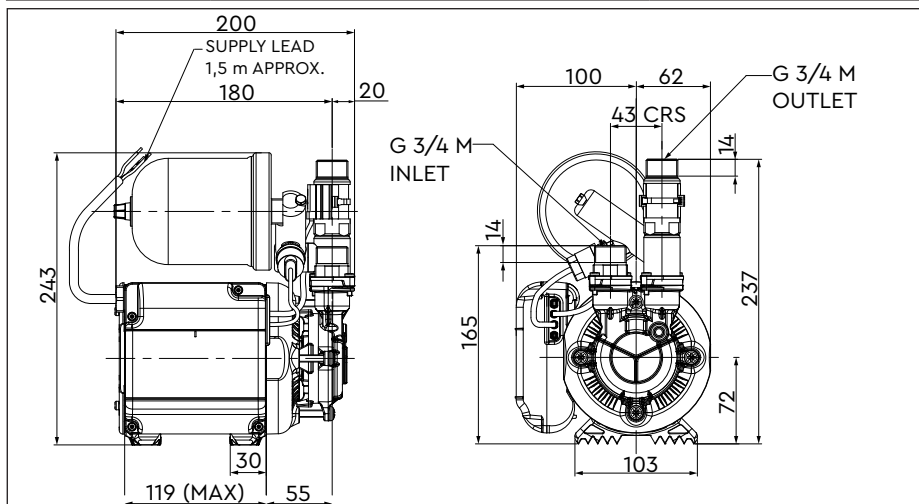

* The maximum pressure that can be applied to the pump under any installation conditions.

** A stored water temperature of 60 °C is considered sufficient to meet all normal requirements and will minimise deposition of scale in hard water areas.

Stuart Turner Limited reserves the right to amend specifications without notice.