



Overview:

Practical high back fireclay cleaner's sink. Designed to withstand heavy use. Ideal for hospitals, schools and other commercial applications.

Key product features:

- Stain and germ resistant
- Made from heavy duty fireclay
- CE Compliant
- Acid and alkali resistant.
- Built in bucket grate included

Product:	20" High back cleaner sink
Product code:	CLEANH20SET
Weight in kg:	57.4
Colour:	White
Material:	Fireclay
Standard:	BS5506/3, EN695, EN37
DOP:	N/A
BiM download:	×
CAD download:	×
Includes:	Chrome effect support legs ,waste kit and support grate

Shown: 20" high back cleaner sink.
CLEANH20SET

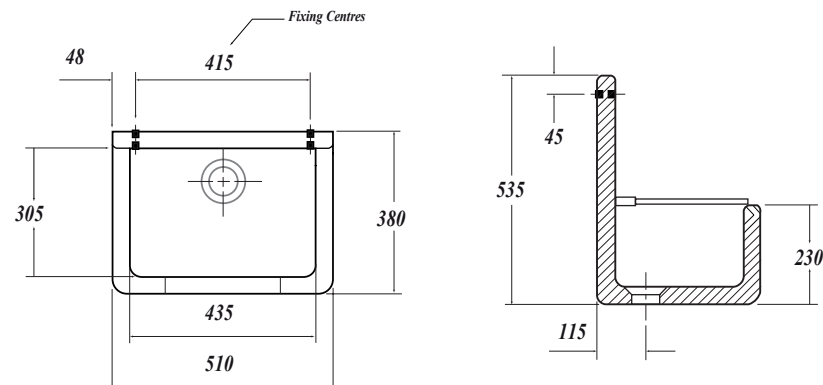

Special notes:

Basin is supplied with support legs kit and waste
- Height of legs 360mm



All dimensions are approximate and subject to normal ceramic variation. Although every effort is made not to change the above product specification, Lecico reserve the right to do so without prior notification if necessary.