

# wasteflo

## Shower Waste Pump - Tiled Floor Gully

Wasteflo shower waste pump and auto gullies provide the perfect solution to the removal of wastewater from any shower, wetroom or level access bathroom where a gravity flow is insufficient.

Wasteflo shower waste pumps are supplied with auto gully, control module, variable speed pump, fixing bracket and high gloss white easy fit cover.



Pump Cover



Pump



Control Module



Tiled Floor Gully



### Features

- Smart technology - variable speed pump control in response to water flow
- Extracts up to 12 litres per minute
- Pumps up to 1 m vertically and 4 m horizontally
- Easy access flow sensor
- Extremely quiet operation
- No commissioning required
- BS 60335 compliant
- CE compliant
- 2 year guarantee (subject to conditions)

### Application

- Designed with 'smart' technology which synchronises the system to remove waste water quietly and is suitable for use with both electric and mixer showers
- Suitable for use in wetroom environments. Extracts up to 12 l/min

# wasteflo

Pump Model		SWP - Tiled Floor Gully 46597
General	Guarantee	2 years
Features	Easy access flow sensor	✓
	Smart technology	✓
	Variable speed pump	✓
Performance	Maximum head	1 metre
	Pumping distance (vertical)	1 metre
	Pumping distance (horizontal)	4 metres
	Maximum flow	12 l/min
	Maximum ambient air temperature	40 °C
	Min / Max water temperature	Min 4 °C / Max 50 °C
Connections	Pump connections	22 mm OD (compression fitting)
Pump	Duty rating	30 mins on / 30 mins off
Electrical	Power supply / phase / frequency	230 V a.c. / 1 / 50 Hz
	Current (full load)	0.3 Amps
	Power consumption	60 Watts
	Fuse rating	4 Amps (pump), 250 mA (transformer)
	Power cable (pre-wired)	1.5 metres
Physical	Enclosure protection	IP55
	Pump	Width: 237 mm, height: 314 mm, depth: 164 mm
	Control unit	Width: 165 mm, height: 150 mm, depth: 76 mm
	Gully	Dia.: 186 mm, height: 79 mm
	Weight (including fittings)	5.9 Kg

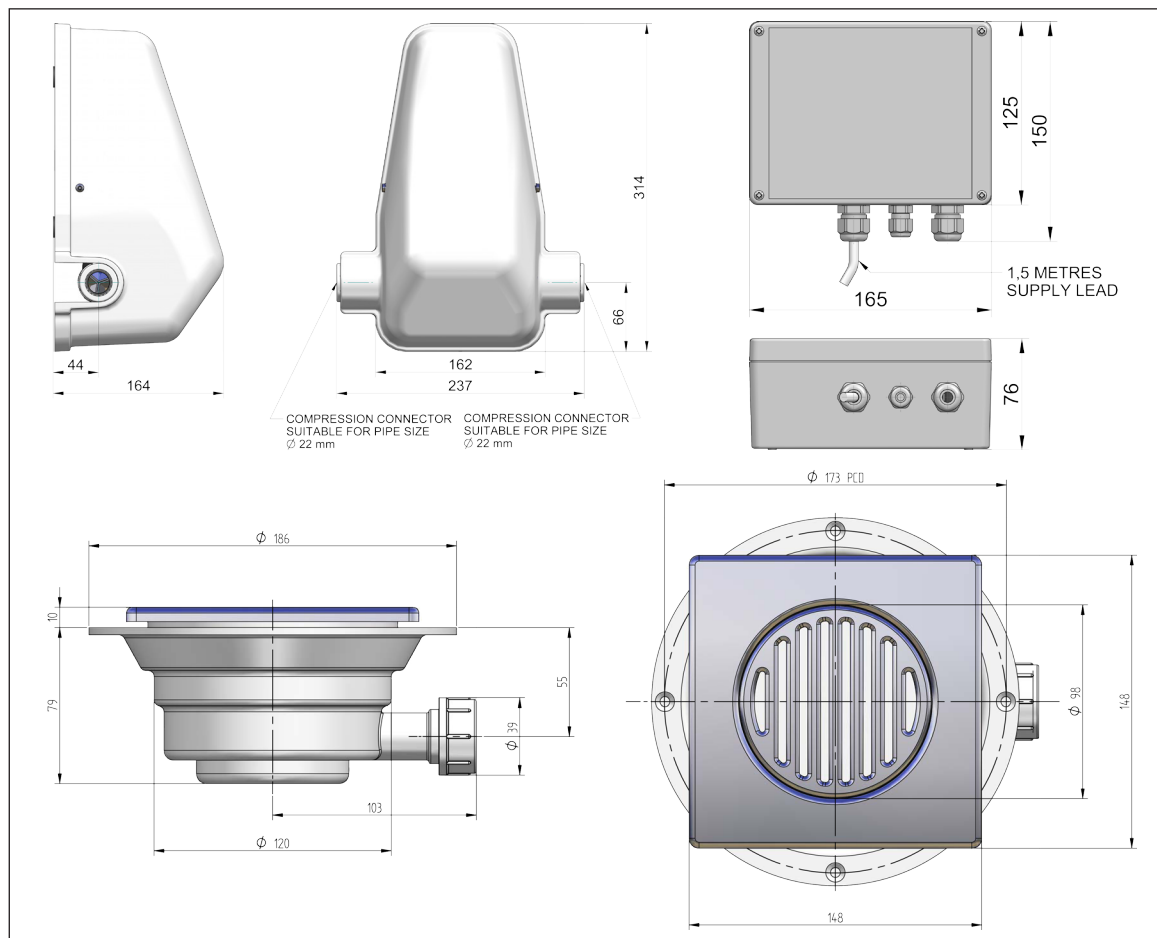

Stuart Turner Limited reserves the right to amend specifications without notice.